

The **Vision Elite** Axle Back is for fleet owner and owner-operator alike, a total chassis optimized through computer-aided design for an excellent strength-to-weight ratio. The cab incorporates exceptional room and comfort with the highest standards of fit and finish. The cab ride is an innovative cab air suspension, for unsurpassed smoothness and comfort. The axle-back configuration contributes to handling ease, while the quiet roomy interior caters to the driver's every need.

- **Conventional Cab**
- **Advantage Chassis**
- **Set-Back Front Axle**
- **6-Wheel Tractor**

Engine: MACK MP8-345C
345 HP [257 kW] Peak Horsepower

Transmission: FULLER, FRO-16210B 10-Speed

Front Axle: MACK FXL12 12,000 lb. [5 443 kg] Capacity

Rear Axle: MERITOR RT40-145 40,000 lb. [18 144 kg] Capacity

MACK

VisionElite

axle back 6x4



Standard Specifications Export

ENGINE: MACK MP8-345C

Peak Horsepower - 345HP at 1400 - 1800 RPM
 Horsepower - 308 HP at 1950 Gov. RPM
 Max. Torque - 1360 lb/ft at 1200 RPM
 V-MAC IV - Total Vehicle Electronics
 Air Compressor - Meritor/WABCO 318 (18.7 cfm)
 Air Cleaner, 11" Single Element
 Dry Type, Under Hood
 Air Intake from Both Sides of Hood
 Alternator, 12V 100A - Delco (24SI)
 Batteries, (3) Mack 12V M/F Group - 650 CCA
 Total 1950 CCA w/Kalas Cables
 Engine Brake - Mack Powerleash
 Silicone Engine Hoses and Tubing
 Poly-V Fan Belt w/Automatic Tensioner
 Fan Drive, Electronically Modulated Type
 Flywheel Housing, Aluminum
 Fuel Water Separator
 Mack EPDM Radiator & Heater Hoses
 Aluminum Radiator
 Starter, 12V Gear Reduction
 Electronic Starter Interlock

CLUTCH: EATON/FULLER, CL7982

15.5" Two-Plate w/Dampened Ceramic Coax
 9-Spring 4-Paddle Driven Disc & 2" Diameter Spline

TRANSMISSION: FULLER, FRO-16210B

10-Speed, Ratios: 11.06 Low - 0.75 High
 Driveline: Meritor 17N HD w/Coated Splines

CAB: CA68 CONVENTIONAL

Air Conditioner w/Integral Heater - R134a Refrigerant
 Air Restriction Monitor, Graduated Lock Up Type
 Air Cleaner Intake Mounted
 Ash Tray
 Cab Mounting
 Four Point System w/2 Air Bags and Shocks at Rear
 Cigar Lighter
 Coat Hook (2)
 Cup Holders, Driver's & Rider's Side
 Dome Lights, 2 Lamps LH/ 2 Lamps RH
 Doors, Galvanized Steel Visibility Doors
 Engine Shutoff - Key Type Control
 Floor Mats, Mack Signature Polyurethane
 Metric Gauges
 Air Pressure Gauge
 Voltmeter
 Digital Gauge Cluster:
 Exhaust Pryometer and Transmission Oil
 Temperature Gauges
 Engine Coolant Temperature Gauge
 Engine Oil Pressure Gauge
 Fuel Level Gauge
 Speedometer, Electronic w/Trip Odometer
 Engine Tachometer Electronic w/Hourmeter



STANDARD SPECIFICATIONS

(Continued)

CAB: CA68 CONVENTIONAL (Continued)

Safety Tinted Windshield, Side and Rear Windows
 Grab Handles, Black Finish RH & LH Behind Door
 Horn, Air Horn Single Tone Electronic
 Identification and Clearance Lights (5)
 Instrument Cluster:
 Segmented LCD Driver's Display
 Instrument Panel, Charcoal Gray
 Interior Trim: Genuine - Slate Gray
 Keys, 2 - Keyed at Random
 Low Air Pressure Indicator, Light and Buzzer
 Exterior Mirrors, Body Colored Aero Mirrors
 w/Integrated Convex Mirror
 Parking Brake On Indicator Light
 Radio Accommodation Package
 Includes: Antenna, Power Supply and 2 Speakers
 CB - 5 way Binding Post
 Seating:
 Driver - Bostrom Talladega 915 Mid-Back Air
 Suspension
 Rider - Mack Fixed Mid-Back Non-suspension
 Seat Belts, Lap and Shoulder w/Cab Mounted Shoulder
 Belt w/Fixed D-Ring for Driver and Rider Seats
 Side Markers - Lamps and Reflectors
 Key Type Starter Switch
 Steering Column, Adjustable Tilt Telescope
 Steering Wheel, Two Spoke Urethane Grip Painted
 Spokes and Bulldog Horn Cap
 Overhead Console, 3 Storage Compartments w/Nets
 Rear Storage Pouch
 Sun Visor, Interior Both Sides w/Ticket Holder
 Turn Signals, Integral w/Fender
 Window Control, Standard Hand Crank
 Windshield - 2 Piece
 Windshield Washers, Wiper Mounted w/Reservoir
 Mounted under Hood
 Windshield Wipers:
 2 Speed Electric Motor w/Intermittent Feature

HOOD & FENDERS:

One Piece Fiberglass w/Wheel Splash Aprons
 SMC (Sheet Molding Compound)
 Grille, Bright Finish Bars w/Black Background

FRAME:

Wheelbase (WB) - 162"
 Load Platform (LP) - 153"
 Cab to Axle (CA) - 96"
 Axle to End of Frame (AF) - 56"
 Frame Rails - Steel
 Cross Section - 10.47" x 3.54" x .24"
 Section Modulus, 11.6 in.³
 RBM (per rail) - 1,390,000 lb. in.
 Tapered and Flanged Rail Ends - 28°
 Bumper: Non-Matelllic Argent with Black Accent
 Bumper to Back of Cab (BBC) - 117"
 Fifth Wheel: Fontaine Air Slide, LH Release
 Front Towing, Clevis (2)

FUEL TANKS:

Capacity/Location: 93 Gallon/LH & RH
 Unpainted Aluminum, 26" Diameter

FRONT AXLE: MACK FXL12

12,000 lb. Capacity
 Tires: 295/75R22.5 (Low Profile)
 Wheel Equipment: (2) 22.5" x 8.25" Alcoa 10-Hole Hub Piloted
 Brakes: Meritor "S" Cam 15" x 4" Q-Plus w/o Dust Shields
 Shock Absorbers
 Slack Adjusters - Automatic
 Suspension:
 Mack Taperleaf 12,000 lb. Ground Load Rating
 2 Leaf Spring
 Steering: TAS-66 TRW Integral Power Steering

REAR AXLE: MERITOR RT40-145

40,000 lb Capacity
 Carrier - Malleable Housing
 Suspension - Maxlite 40EZ 40,000 lb Capacity
 Tires: 295/75R22.5 (Low Profile)
 Wheel Equipment: (8) 22.5x8.25 Alcoa 10-Hole Hub Piloted
 Brakes: Meritor "S" Cam 16.5" x 7" Q-Plus w/o Dust Shields
 Wheel Seals - Oil
 Slack Adjusters - Automatic
 Spring Brake Chambers:
 (2) 30/30 Double Diaphragm Type
 Mechanical Spring Release

AIR/BRAKE:

Dual Air Brake System
 Air Dryer - Meritor System Saver 1200P
 Air Reservoirs - Steel 5600 in³ Capacity
 Single Compartment Primary and Two
 Compartment Supply/Secondary
 Brake Control - 2 Valve Dual Brake System
 Trailer Supply and Tractor-Trailer Park
 Hand Control Valve for Trailer Brake
 Trailer Connection Package: Semi
 (2) 12' Air Hoses w/Integral Glad Hand Electrical Plug Holder
 Storage Bracket
 (1) 12' Seven Wire Cord w/Seven Wire Plug on Each End
 Ground Reachable,
 Breakaway Safety Valve
 Conspicuity Treatment to Back of Cab

ELECTRICAL:

Battery Box - Steel w/Molded Plastic Cover
 Mounted Left-hand side Under Cab
 Courtesy Light Switch - Headlamp and Clearance
 Doubles Trailer Electrical Package
 Electric Circuit Protection Package
 Waterproof Electrical Connections
 Rear Lighting - (2) Combination Stop, Tail Directional and
 Back-Up Lights
 Headlights - Flush mounted Rectangular Halogen Lamps
 w/Lexan Lens, Replaceable Bulbs
 Transistorized Turn Signal Flasher

PAINT:

Cab, Hood and Fenders:
 Mack White (High Gloss)
 Urethane Base Coat w/o Clear Coat
 Chassis Running Gear:
 Mack Black (Urethane)

WEIGHT:

Front: 8,260
 Rear: 6,155
 TOTAL: 14,415

CHASSIS SPECIFICATIONS

(All measurements are in inches)

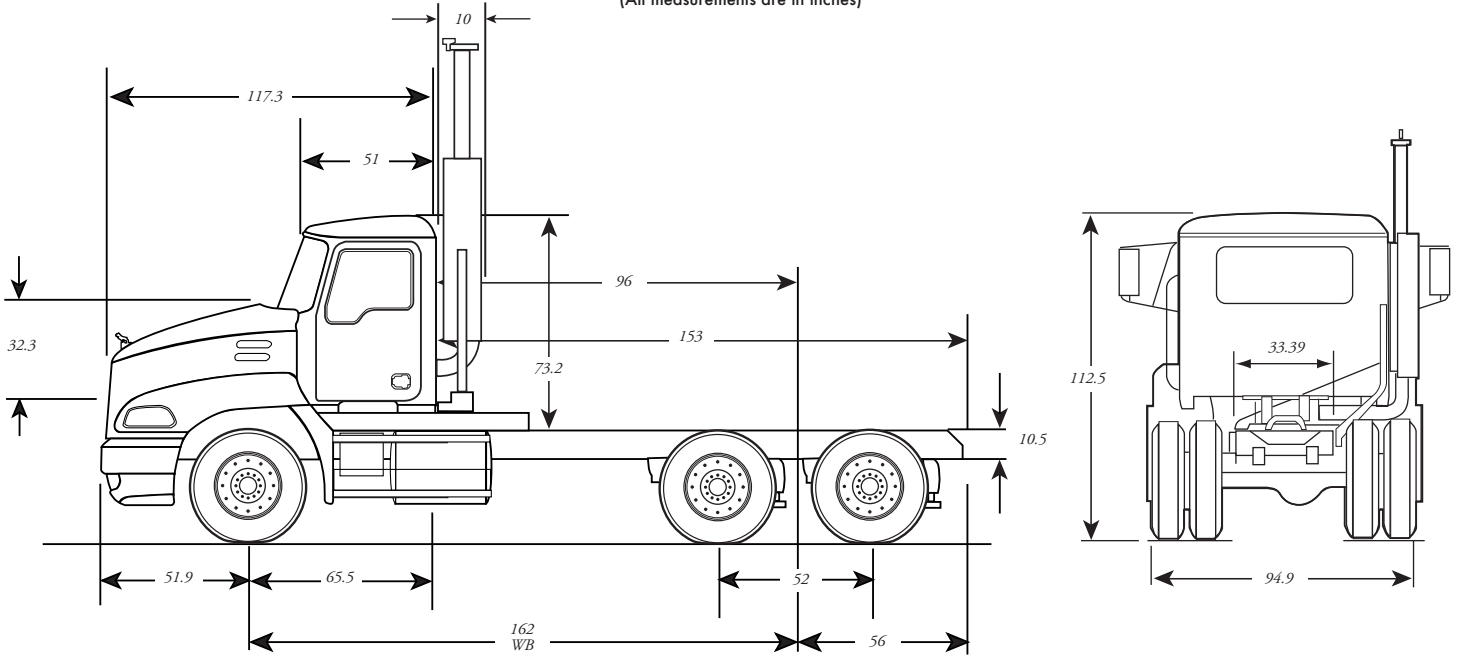

AVAILABLE DRIVELINE COMPONENTS

MP8—ENGINES	
MODEL	HORSEPOWER
MACK	
MP8-345C	345 HP [257 kW] @ 1400 - 1800 RPM 308 HP [230 kW] @ 1950
MP8-360C	360 HP [269 kW] @ 1400 - 1800 RPM 323HP [241 kW] @ 1950
MP8-400C	400 HP [298 kW] @ 1400 - 1800 RPM 358 HP [267 kW] @ 1950
MP8-440C	440 HP [328 kW] @ 1400 - 1800 RPM 389 HP [290 kW] @ 1950

TRANSMISSIONS		
MODEL	SPEEDS	RATIOS (LOW/HIGH)
MACK		
T306G	6	7.50/0.71
T309	9	11.40/0.71
T309(LR)	9	13.93/0.71
T310	10	13.81/0.73
T310M	10	17.35/0.73
T310ME	10	17.35/0.73
T313LR	13	16.42/0.71
T313	13	13.44/0.71
T318LR	18	16.42/0.71
T318	18	13.44/0.71
ALLISON		
4000-HS	5	3.51/0.74
4500-HS	5	4.70/0.76
4000-RDS	5	3.51/0.74
4500-RDS	5	4.70/0.76
4000-HS	6	3.51/0.64
4500-HS	6	4.70/0.67
4000-RDS	6	3.51/0.64
4500-RDS	6	4.70/0.64

TRANSMISSIONS (Continued)		
MODEL	SPEEDS	RATIOS (LOW/HIGH)
EATON FULLER		
RTX-13609B	9	12.57/0.73
RTX-14609B	9	12.57/0.73
RTX-16709B	9	12.46/0.76
FRO-13210B	10	11.06/0.75
FRO-13210C	10	12.69/0.74
FRO-14210B	10	11.06/0.75
FRO-14210C	10	12.69/0.74
FRO-15210B	10	11.06/0.75
FRO-15210C	10	12.69/0.74
FRO-16210B	10	11.06/0.75
FRO-16210C	10	12.69/0.74
RTO-14908LL	10	14.56/0.74
RTO-16908LL	10	14.56/0.74
FR-13210B	10	14.80/1.00
FR-14210B	10	14.80/1.00
RTLO-14913A	13	12.31/0.73
RTLO-16913A	13	12.31/0.73
RT-14915	15	16.94/1.00
RTO-14915	15	13.31/0.79
RTO-16915	15	13.31/0.79
RTLO-14918B	18	14.40/0.73
RTLO-16918B	18	14.40/0.73
EATON FULLER-AUTO SHIFT		
RTO-16910B-DM3	10	10.96/0.74
RTO-14910B-DM3	10	10.96/0.74
RTO-14910B-AS3	10	10.96/0.74
RTO-14910C-AS3	10	12.80/0.73
RTO-16910B-AS3	10	10.96/0.74
RTO-14910C-AS3	10	12.80/0.73
RTLO-14918A-AS3	18	12.19/0.73
RTLO-16918A-AS3	18	12.19/0.73

AVAILABLE DRIVELINE COMPONENTS

(Continued)

AXLES		
CAPACITY	MAKE	MODEL
FRONT AXLES		
12,000 lb. [5 443 kg]	MACK	FXL12
	DANA SPICER	E12021
	MERITOR	FF966
	HENDRICKSON	STEERTEK
14,600 lb. [6 486 kg]	MACK	FXL14.6
	HENDRICKSON	STEERTEK
	MERITOR	FG941

AXLES		
CAPACITY	MAKE	MODEL
TANDEM REAR AXLES/SUSPENSION		
38,000 lb. [17 237 kg]	MACK	S38R
40,000 lb. [18 144 kg]	MACK	S40
	DANA SPICER	DS405(P) DST40(P)/41(P)
	MERITOR	RT40-145(A)
44,000 lb. [19 958 kg]	MACK	S440
46,000 lb. [20 866 kg]	MACK	S440-46/462
	MERITOR	RT46-160 RT46-164EH

OPTIONAL EQUIPMENT

FRAME:

Rail Dimensions: 10.47" x 3.54" x .28"
Section Modulus: 13.3 in.³
Resistance Bending Moment (RBM) 1,600,000 lbs. in.

Rail Dimensions: 10.47" x 3.54" x .32"
Section Modulus: 15.0 in.³
Resistance Bending Moment (RBM) 1,810,000 lbs. in.

Rail Dimensions: 11.81" x 3.54" x .34"
Section Modulus: 20.6 in.³
Resistance Bending Moment (RBM) 2,470,000 lbs. in.

Wheelbase Availability: 144" to 248"

CAB, OPTIONAL INTERIOR TRIM LEVELS:

Trim Level II - Custom: Refer to MackTraq for complete description
Trim Level III - Grand Touring: Refer to MackTraq for complete description

SLEEPER BOXES: Interior Color Matches that of the Cab Interior

- 48" Flat Top
- 56" Flat Top
- 60" Mid Rise
- 70" Mid Rise
- 70" High Rise

AERO AIDS:

- Roof Fairings
- Side Shields

OTHER OPTIONAL EQUIPMENT:

- ABS Options
- Aerodynamic Aids
- Air Dryer Options
- Air Horns
- Air Reservoir, Aluminum
- Alternator Options
- Back of Cab Reflectors
- Back-Up Alarm
- Batter Box Cover, Aluminum
- Battery Disconnect Switch
- Battery Options
- Brake Equipment Options
- Bright Finish Exhaust
- Bright Finish Fuel Tanks
- Bug Screen
- Cab Window Options
- CB Radio Options
- Coolant Protection
- Co-Pilot Driver Information Display
- Crossmember Options
- Dash Mounted Switches
- Daytime Running Lights
- Door Interior Trim Panels
- Dual Exhaust
- Engine Block Heater
- Engine Starting Aid
- Fifth Wheel & Related Equipment
- Fire Extinguisher
- Fog Lights
- Fuel Heater
- Gauge Cluster Options
- Hood Insulation
- Hubodometer
- Identification/Clearance Lights
- In-Dash Storage
- Instrument Panel Trim
- Keyed Alike Chassis
- Keyless Entry
- Mack Road Stability Advantage System
- Mirror Options
- Mud Flaps
- Overhead Console, 2 Compartments

- Permit Plates
- Personalized Name Plate
- Power Windows & Locks
- Push Button Start
- Quarter Fenders
- Reflector Kit
- Seat Options, Driver & Rider
- Side Shield Extensions
- Sliding Rear Window
- Starter Option
- Steering Wheel Options
- Stereo Radio Options
- Storage Console
- Sun Visor, Exterior
- Synthetic Lubricants
- Trailer Hook-Up Lamp
- Wheel Equipment Options
- Wheel Lugwrench
- Windshield Curtain

The information in this brochure was accurate as known as of the date of the publication. Illustrations may not be representative of current product. Mack Trucks, Inc. reserves the right to make changes in specifications, equipment or design, or to discontinue models or options without notice at any time.